

ROSCOE TOWNSHIP
MEETING OF THE TOWNSHIP BOARD
Wednesday, March 12th, 2025– 7:00pm
5792 Elevator Road – Roscoe IL
Regular Monthly Meeting of the Township Board

- I. Call to Order
- II. Pledge of Allegiance
- III. Roll Call
- IV. Public Comments
- V. Approval of Prior Meeting's Minutes – Website Posting to Follow
- VI. Approval of Bills
 - a. Supervisor's Report – Fund and Bank Balances
- VII. New Business
 - a. Approve \$500 to Life Church Food Pantry
 - b. Set Board Meeting Calendar for 2025/26
 - c. Approve Resolution R-2025-3-8 Opposing Township Consolidation
 - d. Set Annual Township Meeting Agenda
 - e. Review / Approve Founders Park Sign Designs / Costs
 - f. Discuss/ Centralizing Township Passwords
- VIII. Reports
 - a. Highway Commissioner's Report
 - b. Clerk's /Sup Asst Report
 - c. Assessor's Report
 - d. Township Attorney's Report
 - e. Cemetery Report
 - f. Historical Society Update
 - g. Activity Coordinator's Report
- IX. Unfinished / Old Business
- X. Public Comments (Restricted to Agenda Items)
- XI. Adjournment

Annual Meeting will be April 8th, 2025, in the Township Offices
Next Regular Meeting will be April 9th, 2025, in the Township Offices

MINUTES OF ROSCOE TOWNSHIP BOARD MEETING

FEBRUARY 12TH, 2025

The meeting was called to order by Supervisor Bob Nowicki at 7 pm. Pledge of Allegiance was said.

Roll Call was taken by the Township Clerk, Gary Blascoe. The following were present; Supervisor Bob Nowicki, Trustees Phil Rhymer, Pat Henderson, Elizabeth Lindquist and Chuck Gilbert.

Also attending were Township Attorney Tom Green, Township Clerk Gary Blascoe, Highway Commissioner Steve Schreier, and Supervisor Assistant Dawn Cassady.

Public Comments: 50 North presentation by Diane LaForge and Rozanne Smith.

Approval of Prior Minutes: A motion was made by Trustee Chuck Gilbert to approve the January 8th, 2025, Regular Meeting Minutes. Seconded by Trustee Elizabeth Lindquist. All in favor, motion carried.

Approval of Bills: A motion was made by Trustee Chuck Gilbert to approve the General Town Bills of \$56,391.38. Seconded by Trustee Elizabeth Lindquist. Roll Call was taken, all voted yes to approve, motion carried. A motion was made by Trustee Pat Henderson to approve the General Road Bills of \$60,937.35. Seconded by Trustee Phil Rhymer. Roll Call was taken, all voted yes to approve, motion carried. A motion was made by Trustee Chuck Gilbert to approve the Cemetery Bills of \$3,822.57. Seconded by Trustee Elizabeth Lindquist. Roll Call was taken, all voted yes to approve, motion carried.

Supervisor's Report-Fund Balances are in the packets.

New Business: Review Plaque Design/Costs-Community Center: A motion was made by Trustee Chuck Gilbert to approve the bronze plaque of \$1704.00 for the Community Building. Seconded by Trustee Phil Rhymer. Roll Call was taken, Supervisor Bob Nowicki voted no, all other

Trustees voted yes to approve, motion carried. Review Cross Bathroom costs: No action was taken at this time. Approve 2024/2025 Audit

Agreement & Schedule: A motion was made by Trustee Chuck Gilbert to approve the Audit Agreement & Schedule of 2024/2025. Seconded by Trustee Phil Rhymer. Roll Call was taken, all voted yes to approve, motion carried. Discuss the Sale of the 2004 Trailblazer: Will keep it in the Township Highway Department.

Highway Commissioner: Sand & salt mix, plus 4 trucks going out in the am. Clerk- I request \$500.00 for the Food pantry at Life Church. Attorney Tom Green states that it needs to be under New Business on the Agenda for next month. Assessor's report: None Township Attorney's Report-None. Cemetery Report-Updated pricing has been done. Historical Society Update, bricking up the wall, two windows have been replaced, bids on insulation for 9 windows are being taken at this time. Activity Coordinator's Report-None

Unfinished/Old Business: Review Sign Design for the Community Bldg. & Cross Home. Trustee Phil Rhymer stated by next month we will have the designs completed for both signs. No action taken at this time.

Public Comments: Trustee Chuck Gilbert asked about the paths around the Community Center.

Adjournment: At 7:36 pm, Trustee Phil Rhymer made a motion to adjourn the meeting, seconded by Trustee Elizabeth Lindquist. All voted yes, motion carried.

Respectfully submitted by Gary Blascoe

Township Clerk

The next Regular Meeting will be March 12th, 2025 in the Township Offices. Immediately following the Budget Hearing at 7 pm.

**ROSCOE TOWNSHIP
GENERAL Monthly Bills Report
February 2025**

Type	Date	Num	Name	Memo	Account	Amount
GENERAL - ALL FUNDS						
General Town Fund						
Assessor						
Bill	02/06/2025	7688	RockIT Computer Services	New Lab Top	Assessor Equip Purchase	1,850.00
Bill	02/11/2025	GOTO FEB 2025	Visa 1173	Yearly Subscription	Computer Maintenance	49.00
Bill	02/20/2025	7716	RockIT Computer Services	Labor & hardware	Computer Maintenance	130.00
Total Assessor						2,029.00
Recreation Fund						
Bill	02/06/2025	1112429	RBG Janitorial	Feb 2025 Facility Maintenance Cleaning	Cleaning CC	260.00
Bill	02/10/2025	9559	Rock River Pest C/C	Pest Control Feb 2025	Maintenance/Repairs CC	120.00
Bill	02/12/2025	4180 6 Feb 2025	Nicor Gas 4180 6 Com. Ctr.	1/10/2025-2/12/2025	Utilities CC	202.99
Bill	02/12/2025	Visa Matchmp2/ 25	Visa 1173	Monthly Charge Feb 2025	Programming CC	20.00
Bill	02/18/2025	FEB 61780912	ComEd 6178091222 C/C	Community Center	Utilities CC	356.32
Bill	02/18/2025	8930423 Feb 2025	ComEd 8930423 Cross House	Feb 2025	Utilities	91.55
Bill	02/24/2025	Feb 2025	T Mobile	Visa Internet C/C 2025 Feb	Utilities CC	50.00
Bill	02/20/2025	12725	Port-a-John	Kelly Meyers-----2/19-3/18 2025	Port a John	120.00
Bill	02/20/2025	U10000195771	GFL Environmental Com Center	Community Center -2/28/25-3/31/2025	Maintenance/Repairs CC	87.83
Bill	02/25/2025	Feb 2025	Tracy Terry	Feb 2025	Cleaning CC	100.00
Bill	02/24/2025	VisaSchnucksCC	Visa 1173	cake brownie game day	Programming CC	24.51
Bill	02/28/2025	10-3-12-6-2024	Four Rivers Sanitation Authority	Wastewater treatment	Utilities CC	346.10
Bill	02/28/2025	12/6 2024-2-7-2025	North Park Water	12-6-2024-2-7-2025	Utilities CC	41.08
Bill	02/28/2025	12/6 2024-2-7-2025	North Park Water		Utilities	13.70
Bill	02/28/2025	23816	Peabody's		Maintenance & Equipment	54.78
Total Recreation Fund						1,888.86
General Town Fund - Other						
Bill	02/06/2025	Feb 2025	Microsoft MS Bill Info Office 365	65%	Office Supplies G/GA/A/GR	164.77
Bill	02/06/2025	Feb 2025	Merchant Fee Service	Monthly Service Fees Feb 2024	Office Supplies G/GA/A/GR	162.88
Bill	02/06/2025	Feb 2025	Zoom	Feb 2024	Office Supplies G/GA/A/GR	15.99
Bill	02/07/2025	721468-0	Mid-City Office Supply		Office Supplies G/GA/A/GR	19.63
Bill	02/06/2025	Feb 2025	Charter Communications		Utilities	71.24
Bill	02/06/2025	Adobe FEB 2025	Visa 1173	FEB 2025 for main office	Computer Maintenance	21.24
Bill	02/04/2025	800104253195	IP Communications Inc	Phones	Utilities	246.14
Bill	02/10/2025	9558	Rock River Pest Control LLC	Feb 2025 Service	Maint Bldg/Equip	90.00
Bill	02/12/2025	79073 Feb 2025	Nicor60124579073 Cross House	Cross House	Utilities	241.43
Bill	02/18/2025	4386998	Mid-City Office Supply		Office Supplies G/GA/A/GR	78.26
Bill	02/18/2025	9060	Automatic Fire Systems Inc	Annual BACKFLOW	Maint Bldg/Equip	283.00
Bill	02/18/2025	Feb 2025	Cleaning Crews	Feb 2025 Service	Cleaning G/GR	165.00
Bill	02/18/2025	Feb 2025	ComEd 0835842	Street Light	Utilities	53.80
Bill	02/18/2025	320000 Feb 2025	ComEd 23100320 General Main	Split 5792 Elevator Road	Utilities	279.35
Bill	02/18/2025	13000 Feb 2025	ComEd 3179130 KM	12585 Wilmington Circle FEB 2025	Utilities	165.57
Bill	02/18/2025	23000 FEB 2025 Path	ComEd 5002323000 HonPath	Honoregan Road	Utilities	202.26
Bill	02/18/2025	7272532222 Feb2025	ComEd 727253 RJCross Park	11588 Cadarbrock Road Cross Park	Utilities	39.72
Bill	02/18/2025	023027427	Xerox Corporation		Office Supplies G/GA/A/GR	26.86
Bill	02/24/2025	Feb 2025	Arthur Agency -Totally Township Website	Website	Office Supplies G/GA/A/GR	74.99

ROSCOE TOWNSHIP
GENERAL Monthly Bills Report
February 2025

Type	Date	Num	Name	Memo	Account	Amount
Bill	02/20/2025	622404 Feb 2024	Comed 6224042 Hom-Path 19067	Bike Path	Utilities	488.08
Bill	02/20/2025	00173968	Entre Computer Solutions	Tech Support	Computer Maintenance	240.00
Bill	02/20/2025	February	Inlitt	Quickbooks Plus Annual Subscription	Computer Maintenance	1,999.00
Bill	02/24/2025	VisaSchnucks	Visa 1173	Coffee and Cleaner/candy	Office Supplies G/GA/A/GR	30.39
Bill	02/26/2025	625622302	Chias First Aid & Safety	Medical supplies to restock cabinet	Office Supplies G/GA/A/GR	17.78
Bill	02/28/2025	Statement No.97	BSLBY Attorneys At Law	Feb 2025	Legal Services G/GA/A/GR	850.50
Bill	02/28/2025	00-173984	Entre Computer Solutions	Tech Support	Computer Maintenance	78.00
Bill	02/28/2025	01-28-2-27 2025	Nicor0059732001	Service for Feb	Utilities	245.84
Bill	02/28/2025	Feb 2025	Lenell's Disposal	Back up and Recovery	Maint Bldg/Equip	75.00
Bill	02/28/2025	00174414	Entre Computer Solutions	Feb 2025 Assessor	Computer Maintenance	115.00
Bill	02/28/2025	Feb 2025	U S Cellular	CBI Bank Analysis	Office Supplies G/GA/A/GR	68.97
Chg	02/28/2025		CBI		Accounting Audit	35.93
Total General Town Fund - Other						6,824.22
Total General Town Fund						10,542.08
Total GENERAL - ALL FUNDS						10,542.08
TOTAL						\$ 18,103.19
Payroll						\$28,645.27

**ROSCOE TOWNSHIP
GENERAL Payroll Summary
February 2025**

	Berner, Debora...	Hawes, Joann L	Loch, Alyssa N	Zintak, Patricia J	TOTAL
Employee Wages, Taxes and Adjustments					
Gross Pay	353.16	850.20	1,212.60	1,085.64	3,501.60
Hourly ASR					
Total Gross Pay	353.16	850.20	1,212.60	1,085.64	3,501.60
Adjusted Gross Pay	353.16	850.20	1,212.60	1,085.64	3,501.60
Net Pay	353.16	850.20	1,212.60	1,085.64	3,501.60
Employer Taxes and Contributions					
Medicare (company)	5.12	12.32	17.58	14.74	49.76
Social Security (company)	21.90	52.71	75.18	63.04	212.83
MRF (company)	0.00	0.00	247.01	0.00	247.01
Total Employer Taxes and Contributions	27.02	65.03	339.77	77.78	509.60

ROSCOE TOWNSHIP Payroll Summary February 2025

	Blasco,...	Cassady, Dawn M	Hanson, Rhonda S	Nowicki, Robert J	Ryan, Mary E	Schreier, Steve A	Servant, Cynthia A	TOTAL
Employee Wages, Taxes and Adjustments								
Gross Pay	0.00	0.00	0.00	0.00	1,384.62	0.00	0.00	1,384.62
Activities Coordinator	541.67	0.00	0.00	1,833.33	0.00	2,083.33	3,384.62	7,842.95
Elected Officials G	0.00	1,100.00	0.00	0.00	0.00	0.00	0.00	1,100.00
Supervisor Assistant	0.00	0.00	1,122.00	0.00	0.00	0.00	0.00	1,122.00
HolidayGen70%..	0.00	0.00	1,806.00	0.00	0.00	0.00	0.00	1,806.00
Hourly 70% Gen	0.00	0.00	0.00	0.00	0.00	0.00	0.00	0.00
Total Gross Pay	541.67	1,100.00	1,918.00	1,833.33	1,384.62	2,083.33	3,384.62	12,245.57
Deductions from Gross Pay								
Dental Ins Employee 2	0.00	0.00	-10.10	0.00	0.00	0.00	0.00	-10.10
Health	0.00	0.00	-250.24	0.00	0.00	0.00	0.00	-250.24
IMRF	0.00	0.00	-86.31	0.00	0.00	0.00	0.00	-86.31
Vision 3 Employee	0.00	0.00	-1.60	0.00	0.00	0.00	0.00	-1.60
Total Deductions from Gross Pay	0.00	0.00	-348.25	0.00	0.00	0.00	0.00	-348.25
Adjusted Gross Pay	541.67	1,100.00	1,569.75	1,833.33	1,384.62	2,083.33	3,384.62	11,897.32
Net Pay	541.67	1,100.00	1,569.75	1,833.33	1,384.62	2,083.33	3,384.62	11,897.32
Employer Taxes and Contributions								
Medicare (company)	7.86	15.95	24.02	26.59	20.07	30.21	49.07	173.77
Social Security (company)	33.59	68.20	102.68	113.66	85.84	129.76	209.84	742.97
Dental Company 2	0.00	0.00	18.90	0.00	0.00	0.00	0.00	18.90
Health Insurance (company)	0.00	0.00	464.72	0.00	0.00	0.00	0.00	464.72
HSA (company)	0.00	0.00	52.50	0.00	0.00	0.00	0.00	52.50
IMRF (company)	0.00	0.00	390.70	0.00	0.00	0.00	0.00	390.70
Vison Company 3	0.00	0.00	2.96	0.00	0.00	0.00	0.00	2.96
Total Employer Taxes and Contributions	41.45	84.15	1,056.38	140.25	105.91	159.37	258.91	1,846.42

ROSCOE TOWNSHIP
Payroll Summary
February 2025

	Hanson,...	TOTAL
Employee Wages, Taxes and Adjustments		
Gross Pay	8.00	8.00
Holiday GA5%	129.00	129.00
Hourly 5%/GA		
Total Gross Pay	137.00	137.00
Deductions from Gross Pay		
Dental Ins Employee 2	-0.72	-0.72
Health	-17.88	-17.88
IMRF	-6.17	-6.17
Vision 3 Employee	-0.12	-0.12
Total Deductions from Gross Pay	-24.89	-24.89
Adjusted Gross Pay	112.11	112.11
Net Pay	112.11	112.11
Employer Taxes and Contributions		
Medicare (company)	1.72	1.72
Social Security (company)	7.33	7.33
Dental Company 2	1.34	1.34
Health Insurance (company)	33.20	33.20
HSA (company)	3.76	3.76
IMRF (company)	27.91	27.91
Vison Company 3	0.22	0.22
Total Employer Taxes and Contributions	75.48	75.48

ROSCOE TOWNSHIP
ROAD & BRIDGE Monthly Bills Report

February 2025

Type	Date	Num	Memo	Account	Amount
Bill	02/06/2025	Feb 2025	Microsoft MS Bill Info Office 365	Office Supplies G/GA/A/GR	63.37
Bill	02/06/2025	3160609	Welders Supply Company	Operating Supplies GR/HR	208.89
Bill	02/07/2025	721468-0	Mid-City Office Supply	Office Supplies G/GA/A/GR	6.54
Bill	02/06/2025	Feb 2025	Charter Communications	Utilities	23.75
Bill	02/10/2025	97117 266810	Brunton's Carquest Auto Parts	Maintenance - Trucks GR	33.24
Bill	02/10/2025	97117 266754	Brunton's Carquest Auto Parts	Maintenance - Trucks GR	195.72
Bill	02/10/2025	29512	Greg's Garage Inc	Maintenance - Trucks GR	51.00
Bill	02/06/2025	25045	JAY'S TRUCK SERVICE INC	Maintenance - Trucks GR	351.55
Bill	02/04/2025	25041	JAY'S TRUCK SERVICE INC	Maintenance - Trucks GR	475.55
Bill	02/04/2025	800104253195	IP Communications Inc	Utilities	82.05
Bill	02/04/2025	551754	Jerry's Auto Parts	Maintenance - Trucks GR	7.95
Bill	02/04/2025	551751	Jerry's Auto Parts	Maintenance - Trucks GR	5.95
Bill	02/07/2025	Visa Menards02072025	Menards - Beloit	Maint Bldg/Equip	62.91
Bill	02/10/2025	6110	Ace Hardware Roscoe	Maint Bldg/Equip	14.99
Bill	02/12/2025	55204	Jerry's Auto Parts	Maintenance - Trucks GR	27.90
Bill	02/12/2025	552049	Jerry's Auto Parts	Maintenance - Trucks GR	13.95
Bill	02/10/2025	551960	Jerry's Auto Parts	Maintenance - Trucks GR	47.15
Bill	02/10/2025	4648	N-Trak Group	Maintenance - Roads GR/HR	442.33
Bill	02/11/2025	6034-179609	O'Reilly Auto Parts	Maintenance - Trucks GR	69.99
Bill	02/14/2025	0220286	Bonnell Industries, Inc	Maintenance - Trucks GR	8,033.90
Bill	02/18/2025	0220337	Bonnell Industries, Inc	Maintenance - Trucks GR	1,724.41
Bill	02/15/2025	552174	Jerry's Auto Parts	Maintenance - Trucks GR	160.25
Bill	02/18/2025	4385998	Mid-City Office Supply	Office Supplies G/GA/A/GR	27.95
Bill	02/12/2025	23748	Peabudy's	Maintenance - Trucks GR	110.34
Bill	02/18/2025	Feb 2025	Cleaning Crews	Cleaning G/GR	55.00
Bill	02/18/2025	320000 Feb 2025	ComEd 23100320 General Main	Utilities	93.12
Bill	02/18/2025	9969032222 Feb 2025	ComEd 996903 R&B	Utilities	512.86
Bill	02/24/2025	Feb 2025	Arthur Agency - Totally Township Websites	Utilities	25.00
Bill	02/20/2025	2373	Peabudy's	Maintenance - Trucks GR	316.27
Bill	02/24/2025	VisaSchnucks	Visa 1173	Office Supplies G/GA/A/GR	10.13
Bill	02/26/2025	525522302	Cintas First Aid & Safety	Office Supplies G/GA/A/GR	53.31
Bill	02/28/2025	Statement No.97	BSL BV Attorneys At Law	Legal Services G/GA/A/GR	283.50
Bill	02/28/2025	01-28-2-27 2025	Nicor00597320001	Utilities	737.52
Bill	02/28/2025	Feb 2025	Lentell's Disposal	Maint Bldg/Equip	25.00
Bill	02/28/2025	Feb 2025	U S Cellular	Cellular Phones GR/G	181.45

ROSCOE TOWNSHIP ROAD & BRIDGE Monthly Bills Report

February 2025

Type	Date	Num	Memo	Account	Amount
Total General Road Fund					
credit	02/28/2025	Feb2025	Monroe truck	Maintenance - Trucks GR	-1,478.37
					13,056.42
Hard Road Fund					
Bill	02/06/2025	5403341650	Morton Sait	SALT Road	4,299.31
Bill	02/06/2025	5403341651	Morton Sait	SALT Road	4,153.32
Bill	02/12/2025	5403355333	Morton Sait	SALT Road	2,161.89
Bill	02/14/2025	5403360763	Morton Sait	SALT Road	2,087.59
Bill	02/13/2025	84758	Smith Oil Corporation	Gas & Oil GR/HR	520.41
Bill	02/13/2025	84758	Smith Oil Corporation	Gas & Oil GR/HR	101.90
Bill	02/13/2025	84759	Smith Oil Corporation	Gas & Oil GR/HR	1,270.40
Bill	02/13/2025	84759	Smith Oil Corporation	Gas & Oil GR/HR	225.28
Bill	02/17/2025	1098639	Welders Supply Company	Operating Supplies GR/HR	197.38
Bill	02/20/2025	0220413	Bonnell Industries, Inc	Operating Supplies GR/HR	299.79
Bill	02/20/2025	022025	Blain's Farm & Fleet	Operating Supplies GR/HR	290.66
Bill	02/20/2025	022025	Menards - Beloit	Operating Supplies GR/HR	120.44
Bill	02/20/2025	12925	Hi Viz Inc	Operating Supplies GR/HR	320.00
Bill	02/20/2025	02242025	Menards - Beloit	Operating Supplies GR/HR	160.44
Bill	02/26/2025	6163	Ace Hardware Roscoe	Operating Supplies GR/HR	33.99
Bill	02/26/2025	6160	Ace Hardware Roscoe	Operating Supplies GR/HR	6.44
Bill	02/26/2025	552455	Jerry's Auto Parts	Operating Supplies GR/HR	53.40
Bill	02/26/2025	552249	Jerry's Auto Parts	Operating Supplies GR/HR	52.50
Bill	02/26/2025	552314	Jerry's Auto Parts	Operating Supplies GR/HR	11.85
Bill	02/28/2025	6181	Ace Hardware Roscoe	Operating Supplies GR/HR	0.89
Bill	02/28/2025	00051135	Occupational Health Centers	Operating Supplies GR/HR	95.00
Bill	02/28/2025	0220617	Bonnell Industries, Inc	Operating Supplies GR/HR	95.18
Bill	02/28/2025	552497	Jerry's Auto Parts	Operating Supplies GR/HR	20.95
Bill	02/28/2025	552490	Jerry's Auto Parts	Operating Supplies GR/HR	35.15
Bill	02/28/2025	552608	Jerry's Auto Parts	Operating Supplies GR/HR	45.35
Bill	02/28/2025	552496	Jerry's Auto Parts	Operating Supplies GR/HR	34.75
Bill	02/28/2025	1022168	RKM Metals LLC	Operating Supplies GR/HR	144.97
Bill	02/28/2025	02282025	Haden Jones	Operating Supplies GR/HR	175.00
Total Hard Road Fund					17,014.23
Total ROAD & BRIDGE - ALL FUNDS					30,070.65
TOTAL					30,070.65
Payroll					29,916.56
Total					\$ 59,987.21

ROSCOE TOWNSHIP
ROAD & BRIDGE Monthly Payroll Summary
February 2025

Employee Wages, Taxes and Adjustments	Abraham, Kris...	Ball, Jeffrey A	Barber, Kerry M	Hanson, Rhon...	Hanson, Tim A	Jones, Haden J	Kiser, Keyran...	Nimmer, Harol...	TOTAL
Gross Pay									
Comp Earned R&B	0.00	0.00	0.00	0.00	0.00	0.00	0.00	0.00	0.00
Comp Paid R&B	0.00	0.00	150.40	0.00	0.00	0.00	0.00	0.00	150.40
Holiday Road 25%	0.00	0.00	0.00	40.00	0.00	0.00	0.00	0.00	40.00
Hourly 25% ROAD	0.00	0.00	0.00	645.00	0.00	0.00	0.00	0.00	645.00
Hourly ROAD	2,250.00	519.75	1,175.00	0.00	3,782.00	3,120.50	3,136.50	5,360.38	19,344.13
Overtime (x1.5)	459.00	0.00	0.00	0.00	0.00	0.00	0.00	0.00	459.00
Personal/Sick Hard Road	297.00	0.00	0.00	0.00	122.00	39.50	143.50	283.63	865.63
Vacation Hard Road	288.00	0.00	0.00	0.00	0.00	0.00	0.00	0.00	288.00
Total Gross Pay	3,294.00	519.75	1,325.40	685.00	3,904.00	3,160.00	3,280.00	5,624.01	21,792.16
Deductions from Gross Pay									
Dental Ins Employee 2	0.00	0.00	0.00	-3.62	-14.44	0.00	-14.44	-14.44	-46.94
Health	0.00	0.00	0.00	-89.36	-357.48	0.00	-357.48	-357.48	-1,161.80
HSA Deduction	0.00	0.00	0.00	0.00	0.00	0.00	0.00	-200.00	-200.00
IMRF	-148.23	0.00	0.00	-30.82	-175.68	-142.20	-147.60	-253.08	-897.61
Vision 3 Employee	0.00	0.00	0.00	-0.56	-2.28	0.00	-2.28	-2.28	-7.40
Total Deductions from Gross Pay	-148.23	0.00	0.00	-124.36	-549.88	-142.20	-521.80	-827.28	-2,313.75
Adjusted Gross Pay	3,145.77	519.75	1,325.40	560.64	3,354.12	3,017.80	2,758.20	4,796.73	19,478.41
Net Pay	3,145.77	519.75	1,325.40	560.64	3,354.12	3,017.80	2,758.20	4,796.73	19,478.41
Employer Taxes and Contributions									
Medicare (company)	47.77	7.53	19.22	8.57	51.18	45.82	42.14	73.22	295.45
Social Security (company)	204.23	32.22	82.18	36.67	218.85	195.92	180.16	313.09	1,263.32
Dental Company 2	0.00	0.00	0.00	6.72	26.86	0.00	26.86	26.86	87.30
Health Insurance (company)	0.00	0.00	0.00	165.96	663.88	0.00	663.88	663.88	2,157.60
HSA (company)	0.00	0.00	0.00	18.74	75.00	0.00	75.00	75.00	243.74
IMRF (company)	670.99	0.00	0.00	139.53	795.24	643.70	668.14	1,145.61	4,063.21
Vison Company 3	0.00	0.00	0.00	1.06	4.24	0.00	4.24	4.24	13.78
Total Employer Taxes and Contributions	922.99	39.75	101.40	377.25	1,835.25	885.44	1,660.42	2,301.90	8,124.40

ROSCOE TOWNSHIP GENERAL Monthly Bills Report

Name: February 2025

GENERAL - ALL FUNDS Cemetery Fund		Type	Date	Num	Memo	Account	Amount
	Bill	02/06/2025	Feb 2025		Microsoft MS Bill Info Office 365	Office Supplies Cemetery	25.34
	Bill	02/20/2025	U10000194679		GFL ENVIRONMENTALPinHill	Waste Removal Pinnacle Hill	97.23
	Bill	02/26/2025	Feb 2025 cemetery		Tracy Terry	Burials Expense Cemetery	25.00
	Bill	02/26/2025	Feb 2025		Michael McGinnis	Burials Expense Cemetery	25.00
	Bill	02/27/2025	Visa Flag store		Visa 1173	Operating Supplies Cemetery	234.32
							406.89
							406.89
							<u>406.89</u>

Roscoe Township Balance Sheet February 2025

General Account Funds

General Town & Assessor Fund			
Beginning Balance from January 2025	801,239.44		
Income received during month	5,460.60		
Expenses approved this meeting	(28,650.23)		
Adjustments			
Ending Balance for February 2025		778,049.81	
General Assistance Fund			
Beginning Balance from January 2025	54,267.22		
Income received during month	40.86		
Expenses approved this meeting	(218.08)		
Adjustments			
Ending Balance for February 2025		54,090.00	
Cemetery Fund			
Beginning Balance from January 2025	88,216.42		
Income received during month	3,991.42		
Expenses approved this meeting	(406.89)		
Adjustments			
Ending Balance for February 2025		91,800.95	
General Account Fund Ending Balance			\$ 923,940.76

Road Account Funds

General Road Fund			
Beginning Balance from January 2025	367,758.08		
Income received during month	276.90		
Expenses approved this meeting	(14,118.67)		
Adjustments			
Ending Balance for February 2025		353,916.31	
Hard Road Fund			
Beginning Balance from January 2025	386,182.85		
Income received during month	290.77		
Expenses approved this meeting	(45,868.54)		
Adjustments			
Ending Balance for February 2025		340,605.08	
Special Bridge Fund			
Beginning Balance from January 2025	640,977.23		
Income received during month	2,910.59		
Expenses approved this meeting	-		
Adjustments			
Ending Balance for February 2025		643,887.82	
Road Account Fund Ending Balance			\$ 1,338,409.21

Roscoe Township Total Fund Balance **\$ 2,262,349.97**

Roscoe Township Total Equity

Roscoe Township Bank Account Balances		
Money Market Account	1,142,163.61	
Checking Account	88,156.23	
Grant Acc	337,718.09	

	Bank Balance	1,568,037.93
	CD Investments	795,478.39
	Outstanding checks	(78,171.73)
	Adjustment (Liabilities)	
Comm Center	Income and Refundable Deposit	(22,994.62)
		<u>2,262,349.97</u>
Recreation	CD Investment Blackhawk	208,418.17 Maturity 06/23/2025
Spec Bridge	CD Investment Blackhawk	587,060.22 Maturity 04/24/2025
		<u>795,478.39</u>

	General Townshi	Maturity	Interest
2/28/2025	\$ 208,418.17		\$ 692.70
1/31/2025	\$ 207,725.47		\$ 690.40
12/31/2024	\$ 207,035.07	6/23/2025	\$ 2,242.33
9/30/2024	\$ 204,792.74		\$ 2,258.55
6/30/2024	\$ 202,534.19		\$ 2,233.64
3/19/2024	\$ 200,300.55	12/18/2024	\$ 49.93
12/31/2023	\$ 200,250.62		\$ 49.91
9/30/2023	\$ 200,200.71		\$ 50.45
6/30/2023	\$ 200,150.26		\$ 50.44
3/31/2023	\$ 200,099.82		\$ 49.32
12/31/2022	\$ 200,050.50		\$ 50.50
9/19/2022	\$ 200,000.00		\$ 53.72
6/30/2022	\$ 430,964.91		\$ 53.72
3/31/2022	\$ 430,911.19	9/19/2022	\$ 53.71
1/6/2022	\$ 430,857.48		\$ 53.70
9/30/2021	\$ 430,803.78	3/21/2022	\$ 53.70
6/30/2021	\$ 430,750.08	9/20/2021	\$ 53.68
3/31/2021	\$ 430,696.40		\$ 265.34
			\$ 737.83

	Special Bridge	Maturity	Interest
2/28/2025	\$ 587,060.22		\$ 2,427.97
1/31/2025	\$ 584,632.25		\$ 2,417.92
12/31/2024	\$ 582,214.33		\$ 2,330.40
11/30/2024	\$ 579,883.93		\$ 2,398.24
10/31/2024	\$ 577,485.64		\$ 2,311.48
9/30/2024	\$ 575,174.16		\$ 2,378.81
7/31/2024	\$ 572,795.35	4/24/2025	\$ 2,368.97
7/31/2024	\$ 570,426.38		\$ 4,561.29
3/31/2024	\$ 565,865.09	7/19/2024	\$ 4,494.06
1/31/2024	\$ 561,371.03		\$ 4,506.97
10/31/2023	\$ 556,864.06		\$ 4,470.79
7/31/2023	\$ 552,393.27		\$ 3,421.67
4/30/2023	\$ 548,971.60		\$ 3,363.34
1/31/2023	\$ 545,608.26		\$ 3,416.55
10/31/2022	\$ 542,191.71		\$ 3,183.84
7/19/2022	\$ 539,007.87		\$ 67.18
4/29/2022	\$ 538,940.69		\$ 67.17
1/31/2022	\$ 538,873.52		\$ 67.17
10/31/2021	\$ 538,806.35		\$ 67.16
8/4/2021 70176894	\$ 538,739.19	1/18/2022	\$ 335.58
4/30/2021 70176894	\$ 538,403.61		\$ 332.42
1/31/2021 70176894	\$ 538,071.19	7/20/2021	\$ 2,792.84
			\$ 13,693.25

11:04 AM

03/05/25

ROSCOE TOWNSHIP
Reconciliation Summary
CBI Bank (TRANSFER ACCT, [REDACTED]), Period Ending 02/28/2025

	<u>Feb 28, 25</u>
Beginning Balance	1,232,042.74
Cleared Transactions	
Checks and Payments - 2 items	-98,000.00
Deposits and Credits - 4 items	8,120.87
Total Cleared Transactions	<u>-89,879.13</u>
Cleared Balance	<u>1,142,163.61</u>
Register Balance as of 02/28/2025	1,142,163.61
Ending Balance	1,142,163.61

11:03 AM

03/05/25

ROSCOE TOWNSHIP
Reconciliation Summary
CBI Bank ██████████ CHECKING, Period Ending 02/28/2025

	Feb 28, 25
Beginning Balance	75,931.96
Cleared Transactions	
Checks and Payments - 121 items	-94,175.70
Deposits and Credits - 11 items	106,399.97
Total Cleared Transactions	<u>12,224.27</u>
Cleared Balance	<u>88,156.23</u>
Uncleared Transactions	
Checks and Payments - 73 items	-113,847.30
Deposits and Credits - 2 items	35,675.57
Total Uncleared Transactions	<u>-78,171.73</u>
Register Balance as of 02/28/2025	<u>9,984.50</u>
New Transactions	
Checks and Payments - 27 items	-26,863.22
Total New Transactions	<u>-26,863.22</u>
Ending Balance	<u>-16,878.72</u>

11:08 AM

03/05/25

ROSCOE TOWNSHIP
Reconciliation Summary
CBI OSLAD GRANT, Period Ending 02/28/2025

	<u>Feb 28, 25</u>
Beginning Balance	337,718.09
Cleared Balance	337,718.09
Register Balance as of 02/28/2025	337,718.09
Ending Balance	337,718.09

11:07 AM

03/05/25

ROSCOE TOWNSHIP
Reconciliation Summary
Blackhawk CD [REDACTED], Period Ending 02/28/2025

	<u>Feb 28, 25</u>
Beginning Balance	207,725.47
Cleared Transactions	
Deposits and Credits - 1 item	<u>692.70</u>
Total Cleared Transactions	<u>692.70</u>
Cleared Balance	<u><u>208,418.17</u></u>
Register Balance as of 02/28/2025	208,418.17
Ending Balance	208,418.17

11:05 AM

03/05/25

ROSCOE TOWNSHIP
Reconciliation Summary
Blackhawk CD# ~~1000000000~~, Period Ending 02/28/2025

	<u>Feb 28, 25</u>
Beginning Balance	584,632.25
Cleared Transactions	
Deposits and Credits - 1 item	<u>2,427.97</u>
Total Cleared Transactions	<u>2,427.97</u>
Cleared Balance	<u><u>587,060.22</u></u>
Register Balance as of 02/28/2025	587,060.22
Ending Balance	587,060.22

ROSCOE TOWNSHIP CALENDAR 2025-26
Second Wednesday of the Month
7pm at the Township Offices

2025

April	8th	2025 Annual Meeting
April	9th	Board Meeting
May	14th	Board Meeting
June	11th	Board Meeting
July	9th	Board Meeting
August	13th	Board Meeting
September	10th	Board Meeting (Publish AUDIT AVAILABLE FOR INSPECTION)
October	8th	Board Meeting – Review & Set Tentative Levies
November	12th	Board Meeting – Final Vote on Levies
December	10th	Review & Set Tentative Budget

2026

January	14th	Board Meeting – Finalize Tentative Budget
February	11th	Layover Period for Budget
March	11th	2025/26 Budget Hearing / Board Meeting: Set Monthly Calendar For 2025/26; Set Annual Meeting Agenda
April	8th	Board Meeting
April	14th	2026 Annual Township Meeting

ANNUAL MEETING
APRIL 8th, 2025
7:00 PM
Township Hall, 5792 Elevator Road, Roscoe
AGENDA

CALL THE MEETING TO ORDER – CLERK GARY W. BLASCOE

ELECTION OF MODERATOR

SWEARING IN OF MODERATOR

ADOPTION OF AGENDA

READING OF THE MINUTES

APPROVAL OF THE MINUTES

THE ANNUAL REPORT – SUPERVISOR BOB NOWICKI

APPROVAL OF THE ANNUAL REPORT

ROAD COMMISSIONER REPORT

CEMETERY BOARD REPORT

ASSESSOR REPORT

QUESTIONS AND COMMENTS FROM THE FLOOR

ADJOURNMENT

NEXT ANNUAL MEETING WILL BE APRIL 14th, 2026

ROSCOE TOWNSHIP COMMUNITY CENTER MONUMENT SIGNS

4562 HONONEGAH ROAD
ROSCOE, ILLINOIS 61073

02/24/2025

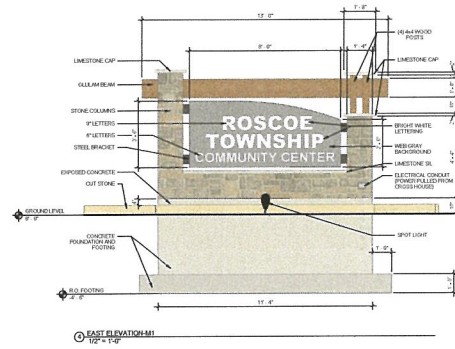
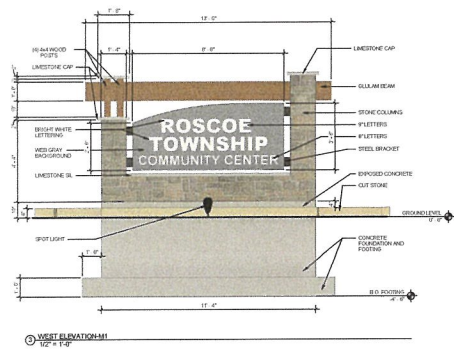
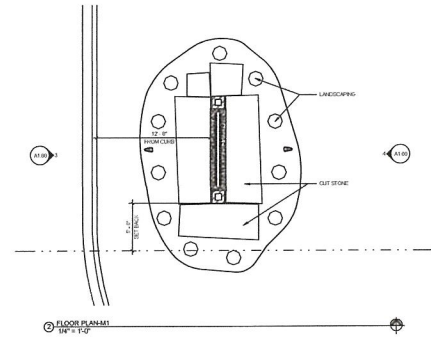
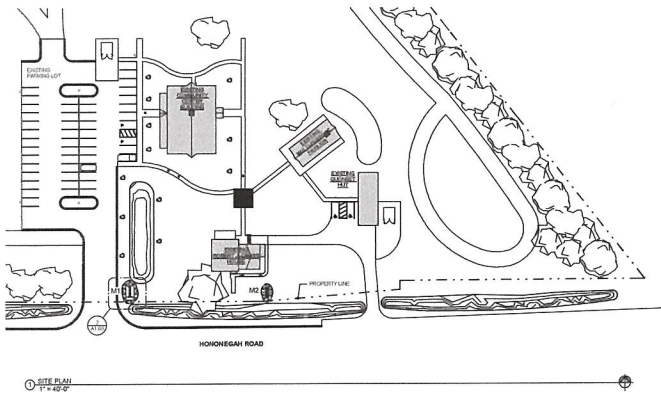

M1 - SITE PLAN & ELEVATIONS

SCALE: As Indicated
PROJECT NUMBER: 20003 00
DATE: 02/19/2025
© Copyright 2025
This document is the copyrighted property of Saavedra Group Architects and may not be copied or used by any person without written permission.

FRENCH SCALE
CAUTION: IF THIS BAR DOES NOT MEASURE EXACTLY
1" THESE DRAWINGS ARE NOT FINISHED TO SCALE

Saavedra
Group
Architects
Architecture • Engineering • Management

504 North Church Street
Rockford, Illinois 61103
815-963-9392

www.sgadesign.com
20240202 2:28:36 PM

ROSCOE TOWNSHIP COMMUNITY CENTER MONUMENT SIGNS

4562 HONONEGAH ROAD
ROSCOE, ILLINOIS 61073

02/24/2025



MONUMENT SIGN - M1 3D VIEW

SCALE: PROJECT NUMBER: 20001.00 PRINT SCALE: 08/09/23
CAUTION: IF THIS BAR DOES NOT MEASURE EXACTLY 1" THESE DRAWINGS ARE NOT PRINTED TO SCALE.
© Copyright # 2025
This document is the copyrighted property of Saavedra Group Architects and may not be copied or used by any person without written permission.

Saavedra
Group
Architects
Architecture • Engineering • Management

504 North Church Street
Rockford, Illinois 61103
815-963-9392

www.sgadesign.com
224222 2:28:10 PM

ROSCOE TOWNSHIP COMMUNITY CENTER MONUMENT SIGNS

4562 HONONEGAH ROAD
ROSCOE, ILLINOIS 61073

02/24/2025

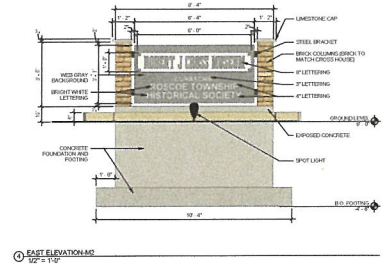
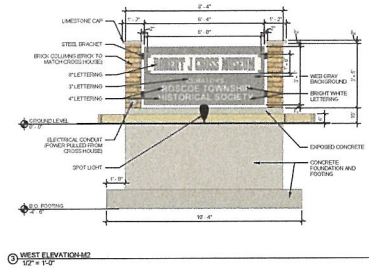
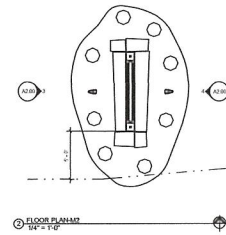
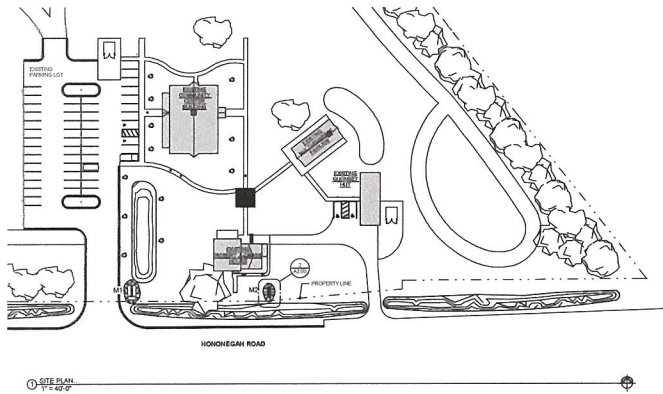

M2 - SITE PLAN & ELEVATIONS

SCALE: As Indicated
PROJECT NUMBER: 2000.00
DATE: 02/19/2025
© Copyright 2025
This document is the copyrighted property of Saavedra Group Architects and may not be copied or used by any person without written permission.

FIRST SCALE
CAUTION: IF THE BAR DOES NOT MEASURE EXACTLY
1" THESE DRAWINGS ARE NOT FIRST TO SCALE.

**Saavedra
Group
Architects**
Architecture • Engineering • Management

504 North Church Street
Rockford, Illinois 61103
815-963-9392
www.sgadesign.com
2/24/2025 2:38:39 PM

ROSCOE TOWNSHIP COMMUNITY CENTER MONUMENT SIGNS

4562 HONONEGAH ROAD
ROSCOE, ILLINOIS 61073

02/24/2025



 Saavedra Group Architects

MONUMENT SIGN - M2 3D VIEW

SCALE:
PROJECT NUMBER: 20003.00
000023
© Copyright 2023
This document is the copyrighted property of Saavedra Group Architects and may not be copied or used by any person without written permission.

PRINT SCALE:
CAUTION: THIS BAR DOES NOT MEASURE EXACTLY
† THESE DRAWINGS ARE NOT PRINTED TO SCALE

 Saavedra
Group
Architects
Architecture • Engineering • Management

504 North Church Street
Rockford, Illinois 61103
815-963-9392

www.sgadesign.com
02/24/2025 2:38:58 PM